

Viking  
Enviroclad

keeping  
water on the  
outside

Roofspec  
Viking

Taking care of detail

[www.vikingroofspec.co.nz](http://www.vikingroofspec.co.nz)



Enviroclad: Dove Grey

## **Viking Enviroclad:** **world-class proven performer**

**Viking Enviroclad offers absolute watertight integrity for low-slope roofs. It is a TPO (thermoplastic polyolefin) waterproofing membrane, rendering all the necessary attributes of a world-class system, from waterproofing to aesthetic and environmental elements.**

The benefit for building owners is Viking Enviroclad's proven performance in New Zealand conditions. It has been tried and tested both internationally and locally, having been installed on thousands of homes and buildings worldwide for over 25 years and across New Zealand and the Pacific since 2007.

Viking Enviroclad is manufactured by the world's largest and most technologically advanced manufacturer of waterproofing membranes, Carlisle Construction Materials.

Viking Enviroclad is a mesh-reinforced, thermoplastic, heat-weldable waterproofing membrane that can be installed on most new substrate surfaces, as well as over many existing membranes.

Viking Enviroclad possesses strong UV and puncture resistance properties and the reinforcing mesh provides latitudinal strength, meaning Enviroclad is extremely forgiving of structural movement.

Viking Enviroclad is suitable for low-slope and pitched roofs, gutters and parapets, pond liners, balconies, under floating decks and roof gardens of commercial and residential buildings. Viking Enviroclad can also be used as the waterproofing membrane for Viking's WarmRoof and WarmSpan systems.

# Superior quality: delivering greater benefits

## Energy Saving

Viking Enviroclad is highly-reflective, with the white surface option reflecting over 90% of the solar radiation that hits it. This will directly contribute to a reduction in the energy required to cool a building's interior.

Viking Enviroclad can be used as the waterproofing membrane for Viking's WarmRoof and WarmSpan systems, which will achieve even greater energy savings through their insulation components.

In the USA, Enviroclad is US ENERGY STAR® rated and Cool Roof Rating Council certified. In New Zealand, Viking Enviroclad is CodeMark certified and BRANZ appraised.

The reduction in energy consumption has been proven to positively contribute points to a building's Green Start rating.



## Water Tight Integrity

Viking Enviroclad's heat-weldability (vulcanised at 400°C) creates stronger and flatter seams.

This technology also renders quicker installation time while ensuring watertight integrity, even when fully immersed.

## System features

- 100% recyclable
- High UV resistance
- High reflectivity
- Water potability certified
- 100% recyclable
- Formulated to suit a wide range of climatic conditions
- Compatible with Viking WarmRoof and Viking WarmSpan systems
- Cut to length
- Installed only by Licensed Installers
- Mesh scrim inherent in membrane sheet for latitudinal strength
- 20-year product warranty
- CodeMark certified
- BRANZ appraised
- Heat-weldable seams
- Custom-made weldable accessories
- Overlay Option
- Enviroclad-specific licensing school in Auckland
- Wide rolls – (up to 3.66m) = less seams
- Long rolls – (30.4m) = less seams
- Enviroclad-specific licensing school

## Environmental Benefits

Viking Enviroclad is 100% recyclable, due to the absence of chlorinators and plasticiser in the composition of the product.

During the manufacturing process, off-cuts are recycled. Enviroclad is also supplied cut-to-length if requested, meaning minimal waste.

Viking Enviroclad is potability certified, meaning drinking water can officially, but more importantly, safely be collected off an Enviroclad roof.

The fact that Enviroclad is heat-welded negates the need for oil-based splicing systems like tapes and primers. It can also be installed using mechanical fastenings, negating the use of adhesives if desired.

## Comprehensive Quality Assurance

Viking Enviroclad is backed by a 20 year warranty and your project may be eligible for the Viking Full System Warranty.\*

The Full System Warranty covers both the materials plus the installation in one document for the building owner.

\*Conditions Apply



Viking  
**Approved**  
Applicator

# Viking Roofspec offers the largest colour range in New Zealand's TPO market

Note – The colours shown in this brochure are a digital representation of the actual colours. Before making a final selection, Viking Roofspec recommends viewing actual material samples and/or existing roof installations.

## Standard colour range

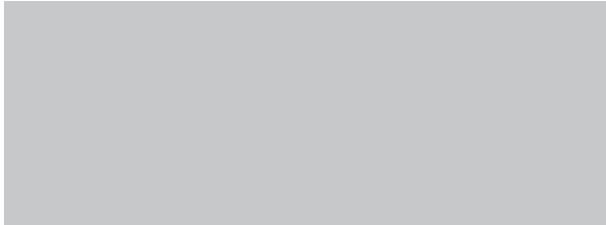

Dove Grey

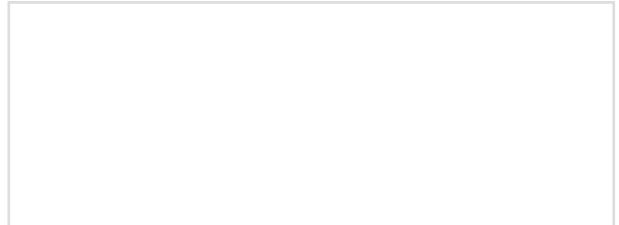

White

## Exciting new earth tone colour range

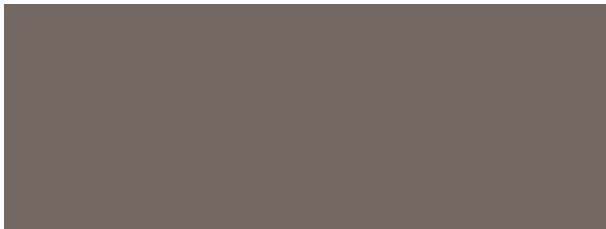

Mansard Brown

### Mansard Brown

This tone complements a building where natural products have been used as cladding. It also allows the building to blend in with natural surroundings. Mansard Brown is well suited to all climate zones, but being a darker membrane, it is especially suited to cooler regions as it is more heat-absorbent.



Rock Brown

### Rock Brown

The lightest tone of the four new colours, Rock Brown offers property owners warmth and versatility; especially when trying to blend the property into a natural backdrop. This colour also complements warm-toned cladding options, including brick, stone and timber.



Slate Grey

### Slate Grey

A Slate Grey membrane combines well with natural claddings such as weatherboards, cedar, stone, brick or copper. This colour tone reduces the glare due to its darker tint. Like the other colours, it's well suited to any region; especially the cooler zones.



Patina Green

### Patina Green

In New Zealand's predominantly green landscape, our Patina Green Enviroclad is an ideal choice if a property is surrounded by forestry or bush. It allows the building to match the landscape and tastefully blend into rural environments.

To order a colour range sample box please email [info@vikingroofspec.co.nz](mailto:info@vikingroofspec.co.nz) or phone 0800 729 799



## Enviroclad colours: striking earth tone colour range

**Viking Roofspec now offers Enviroclad TPO in four new earthy colour tones, providing architects and building owners versatility for the aesthetics of their designs and buildings respectively.**

**Not all flat roofs are unseen, these colours can add extra flare to a surface that would normally have been Dove Grey or White.**

### Advantages of specifying a coloured membrane

- The opportunity to make a visual statement
- Provides flexibility and versatility to colour schemes
- Earthy tones blend more tastefully in rural, bush and coastal areas
- Earthy coloured membranes complement natural construction materials
- Assists with compliance in those councils zones where cladding shade L.R.V.s (light reflective values) can't exceed 40 LRV
- Provides minimal glare from the roof, a 'neighbour-friendly' option if their home/building looks down on to it

This new colour range allows you to complement other construction materials such as timber, stone or copper; all with tones found in natural surroundings.

Our coloured Enviroclad range offers the same watertight integrity as standard Dove Grey or White Enviroclad.

# Why be normal when you can be different?

**Viking Enviroclad has created a visual statement for a home, while allowing it to blend in amongst its natural backdrop**

## **THE CHALLENGE**

A beautiful cliff-edge home overlooking New Zealand's iconic Piha beach needed a new roof - the old one had fulfilled the Building Code's minimum 15 year durability requirement, and was beginning to perish in places and needed to be replaced.

The homeowners were looking for a solution that would waterproof their home without causing too much disturbance, or change the look drastically. With that in mind, the most convenient option was to re-roof their home with Dove Grey Enviroclad, until their waterproofing applicator suggested something new and exciting .... the choice of four new earthy coloured membrane options.

## **THE SOLUTION**

As soon as the homeowners saw the Mansard Brown shade, they instantly knew their home was meant to feature this new Enviroclad colour – being the first home in New Zealand to do so.

This particular dark-brown shade complements the dark timber cladding, while allowing the roof to blend in with the surroundings, giving those homes situated above a more natural shade to look down upon.

This particular roof has a slope of 22 degrees; a slope that would normally be clad with traditional roofing materials such as long run steel or tiles. Due to the versatility and flexibility of Enviroclad TPO membrane as well as its durability in this coastal situation (non corrosive in a salt spray zone); it was the perfect solution.





After a through inspection, the approved applicator established that the original substrate was still in good condition, so all he had to do, was remove the old membrane, and replace it with Viking Enviroclad.

### **THE RESULT**

Choosing a coloured roofing membrane has allowed the homeowners to veer away from traditional roofing colour schemes, creating a visual statement for their home while blending in amongst its natural backdrop— all with the knowledge that their non-corrosive membrane roof is perfect for coastal conditions and backed with a 20 year product warranty.



# Alternative Viking Enviroclad: solutions to meet your needs

## Viking Enviroclad APEEL

Viking Enviroclad factory applied APEEL protective film, temporarily guards the surface of the membrane from scuffs and dirt accumulation during installation and subsequent construction process. On completion the protective front layer is peeled off by the roofing applicator to leave a pristine shiny roof surface.

### Durable and easy

Enviroclad APEEL protective film will stay in place until it is ready to be removed. Strong adhesion levels allow the film to stay in place for up to three months, resisting the effects of heat, UV exposure, rain and wind. Once the film is removed, no residue remains on the membrane, providing the building owner with a clean, reflective roof that will continue to resist dirt pick-up long after installation.

APEEL is ideal for re-roofing and new construction projects.

### Time and Labour Savings

It is understandably common practice for building owners to request that their new membrane roof be cleaned before they pay for it. With Enviroclad APEEL, there is no need for an applicator to go through the labourious; sometimes toxic; and imperfect cleaning or power-washing process after installation. They simply remove the film, and the roof is ready for final inspection.

Enviroclad APEEL is available in both 1.14mm and 1.52mm thicknesses, in 3.05m wide and in grey (white is available on indent).



## Viking Enviroclad F.B.S. (fleece-backed system)

Viking Enviroclad FBS is a waterproofing membrane where a 'fluffy' polyester layer has been factory-laminated to the underside of the waterproofing membrane.

Enviroclad FBS is recognised as one of the best re-roofing solutions for overlaying on top of a wide-range of existing roof surfaces such as old bitumen, malthoid or rough substrates such as concrete and tongue and groove sarking.

Enviroclad FBS (fleece-backed system) is a membrane re-roofing solution consisting of 1.4mm of polyester fleece-backing factory-laminated to 1.14mm of TPO (thermoplastic polyolefin).

### Silk Purse

The fleece-on the membrane's underside bonds with the substrate, partially forgiving the rough surface into which it beds itself, rendering a surprisingly smooth, aesthetic membrane surface finish. An unsightly, rough substrate would otherwise 'telegraph' more of its imperfections through the surface of any non-fleece backed single-ply membrane.

### Reduction in Waste

In many instances, there is no need to dump the old roof surface, as FBS can be applied over a wide-range of existing roof surfaces\* leading to a reduction in waste, as the old roof surface doesn't fill-up our local landfills.

### Reduction in Cost and 'Churn'

Overlaying an existing membrane means there are no costs involved in stripping the current surface; redesigning, reconditioning or reconstructing the existing roof. This also avoids exposing the interior to adverse weather conditions – or relocating people while the overlay takes place – an expensive process also known as 'churn'.

### Puncture Resistance

The fleece-backing of the FBS membrane adds additional puncture resistance to the existing puncture resistance of the Viking Enviroclad membrane, possessing a 33% greater puncture resistance than most high puncture resistant membranes.

\*Only if an invasive investigation has confirmed the integrity of the substrate. Please note: decayed substrates require complete replacement.





**RhinoBond machine**

## RhinoBond induction welded mechanical fastening

In line with the construction industry's continuous evolution, there are a growing number of substrate options onto which membranes are installed.

A common question is whether Enviroclad can be laid over substrates other than plywood, concrete or rigid insulation. The main issue is adhesion. With the RhinoBond method of fixing, you can be certain that the strongest possible adhesion will be achieved.

### What is RhinoBond?

RhinoBond is induction fastening technology, an alternative method of mechanically-fastening Enviroclad membrane to a wide range of substrates. The difference from other types of mechanical fastening is that it doesn't involve penetrating the membrane.

### How does it work?

TPO-coated metal plates are fastened to the substrate in a grid pattern. Enviroclad membrane is laid over the plates and appropriately positioned on the roof as per a normal installation. The RhinoBond induction welding tool is placed above each of the RhinoBond plates (which are underneath the membrane surface).

### How RhinoBond works

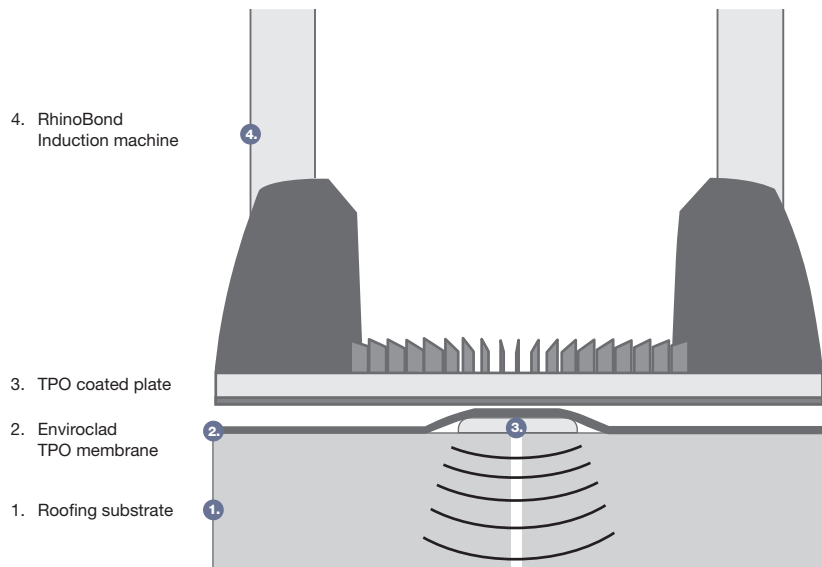

The induction tool emits an electro-magnetic charge through the membrane, which activates the TPO coating on the surface of the plate below, resulting in a weld between the plate surface and the underside of the membrane (in less than five seconds). Weighted magnets are then temporarily placed over the plates to dissipate heat and ensure intimate contact between the bottom surface of the membrane and the integral hot-melt TPO coating on the plate's surface. This results in a superb weld.

### Benefits of RhinoBond

- No adhesive required
- No membrane penetration
- Improved productivity – due to less fasteners and plates required than traditional mechanical fastening
- Maximum wind uplift resistance
- No narrow perimeter sheets required
- Negates membrane flutter
- Symmetrical wind load distribution
- Negates membrane fatigue at seams
- No weather or temperature dependence

## CASE STUDY: Viking Enviroclad APEEL



before



after

# “I’d like an ‘APEEL – Rhino – Warm Roof’ Combo please!”

## THE CHALLENGE

A large nursing home in central Auckland had thousands of square metres of metal tray roofing with minimal pitch that was in a state of despair and leaking. These roofs needed to be sorted, but firstly, there were a couple of challenges:

**Budget:** The trust board didn’t have income for the metal roof to be removed nor for carpenters to build a support structure to re-pitch a new one at the three degrees required for metal roofs.

**Practicality:** Removal of a roof requires the relocation of people, an inconvenient and expensive, especially when elderly patients are involved.

**Noise:** Projects like this can be noisy, the last thing people in the twilight of their lives need to be subjected to.

**Safety:** The buildings have a number of extractor fans, so the fumes from an adhesive system could find their way into a building and affect the patients and staff.

**Damage:** A number of other trades would be following the roofing project, so there was a danger the membrane surface could be damaged.

## THE SOLUTION

A warm roof overlay was proposed to be installed on top of the existing roof. The existing metal tray roof would remain in place so the building would remain covered and no building patients or staff would need to be relocated.

The Polyiso insulation provided a flat surface for the membrane to be installed on and rendered an R-value of R-3.0, making the building more energy efficient and comfortable for the patients.

Fumes! To eliminate the use of potent adhesives, the RhinoBond mechanically-fastening system was commissioned. This state-of-the-art system prevented membrane penetration and maximised wind uplift resistance.

To avoid other tradie damage, Viking specified the use of Enviroclad APEEL, a factory applied protection film that is simply peeled off on construction completion, leaving a pristine membrane surface.

## THE RESULT

The nursing home trust board members were thrilled with the fact they ended up with a low slope roof that was:

- Waterproof
- Energy-efficient through Viking WarmRoof
- Solvent-free through the use of the RhinoBond mechanical fastening system
- Pristinely-finished thanks to Enviroclad APEEL
- Backed by warranties of substance

The installation of this three-system re-roof had been achieved with minimal noise and disruption, and most importantly, without the expensive and painful process of having to remove the existing roof and relocate its precious elderly inhabitants respectively.

# Viking Enviroclad Product Features

## World Class Manufacturer

Carlisle Construction Materials of the USA is one of, if not the largest, manufacturer of EPDM and TPO waterproofing membranes in the world. Carlisle has been supplying the international market-place with world-class materials since the 1960s. It has a policy of aligning itself with distributors with similar values (like Viking); two of those values being a relentless emphasis on training along with the mantra of sticking with accredited 'systems' empirically tested in some of the world's most sophisticated laboratories.

## Viking's Licensing Programme

Viking Enviroclad is installed exclusively by Viking Approved Application companies. Every individual installer of Viking's membranes has been licensed at Viking's Licensing School.

No installer has access to these materials unless he or she has been licensed. This policy has been instrumental in Viking Enviroclad having one of, if not the lowest, remedial rate in the industry.

## Comprehensive Quality Assurance

Viking Enviroclad is backed by a 20 year warranty and your project may be eligible for the Viking Full System Warranty.\*

The Full System Warranty covers both the materials and the installation in one document for the building owner.

\*Conditions Apply

## Proven Record

Having been launched internationally in 1990 and introduced in NZ in 2007, Viking Enviroclad has been successfully installed, and continues to perform superbly on buildings for significant organisations such as: Fonterra; Courier Post; Genesis

Energy; Foodstuffs; Progressive Enterprises; Ryman Healthcare; Metlifecare; Ministry of Justice; Department of Corrections; Te Wananga O Aotearoa and Ballance Fertilisers to name a few.

## Weldable Accessories

Viking Enviroclad is supplied as a complete system with a range of heat-weldable accessories to deal meticulously with changes in roof plane direction such as internal and external corners. It also comfortably flashes roof penetrations such as pipes; air conditioning units and substrate vents.

TPO Weldable walk way rolls with a tread-plate pattern are specified to provide further protection to the roof surface by directing the flow of foot traffic when the roof is being inspected or serviced.

## Product Specification

	Enviroclad	Enviroclad FBS	Enviroclad APEEL
Thickness	1.14mm and 1.52mm	2.5mm (including 1.4mm of fleece-backing)	1.14mm and 1.52mm
Roll Width	3.05m (all colours) and 3.66m (grey only)	3.66m	3.05m
Roll Length	30.4m	30.4m	30.4m
Colour	Grey, White (both thicknesses) Mansard Brown, Patina Green, Rock Brown, Slate Grey (1.52mm thick only)	Grey and White	Grey
Cut-to-length	3.05m wide only	Yes	Yes
CodeMark Certified	Yes		Yes
BRANZ Appraised	Yes	Yes	Yes
Water Potable	Yes	Yes	Yes
Product Warranty	20 Years	20 Years	20 Years
Licensing Programme	Yes	Yes	Yes



masterspec





**Contact us here  
to meet your needs**

Phone 0800 729 799

Fax 0800 729 788

[info@vikingroofspec.co.nz](mailto:info@vikingroofspec.co.nz)

[www.vikingroofspec.co.nz](http://www.vikingroofspec.co.nz)

**Auckland office**

80 Alexander Crescent, Otara  
PO Box 14-541, Panmure  
Auckland 1741, New Zealand

**Christchurch office**

2 Nazareth Avenue, Middleton  
PO Box 9117, Tower Junction  
Christchurch 8149, New Zealand